

The G-COAT 421 has been designed for coating for large-size meshes without compromising on quality, in a fully automatic and safe manner



G-COAT 421

Grünig

Grünig-Interscreen AG
Ringgenmatt 14
CH-3150 Schwarzenburg
Switzerland

Phone +41 31 734 2600
Fax +41 31 734 2601
www.grunig.ch
mail@grunig.ch

G-COAT 421

Automatic coating machine XL



Execution A2

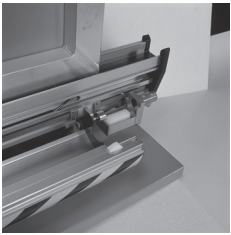

Option R



Touch-Screen Terminal

Particular features:

- Simple operation and introduction of all the parameters via a touch screen terminal.
- 50 freely configurable programs are available.
- Unique and extremely rugged construction with special aluminum profiles. Simple loading possible from both sides, with slight loading height. Optimal choice for large-size formats with a maximum width of 5000 mm and height of 8000 mm.
- The patented coating head allows an optimal contact pressure at the center of the screen and guarantees a regular build-up of the layer even in the event of large screens (Pat.No. 0608661)
- Drive unit with toothed belt requiring only a minimum of maintenance, with guide profiles of special synthetic material.
- Length measuring system for all drive units. Programmable upper frame holder for the desired frame height. Upon pressing a button, the coating troughs move to the optimal filling position.
- The frame height, screen profile height and wiping height of the layer can be individually programmed. The wiping height of the coating troughs is automatically offset.
- The separate actuation of both coating troughs allows to coat the mesh from the squeegee side, from the print side or from both sides. Highest possible reproducibility of the coating results (tolerance +/- 1 μ).
- Extremely torsion-free trough supporting profiles with pre-stressing mechanism.
- Programmable trough contact pressure for the coating process.
- Pneumatic clamps on top and at the bottom for an optimal fastening of the screen frames. The stretching units can be laterally adapted to the desired frame size. The clamping units are controlled via a foot-operated pedal.
- Extremely robust screen reception unit with special profiles and integrated sliding bands.

Execution A1

- Standard execution

Execution A2

- The version with automatic hot air dryer allows an intermediate drying during layer build-up. It is equipped with its own drive unit and acts from the printing side, independently of the coating carriage. The speed and number of strokes can be programmed.

Option MD

- The modem allows a remote diagnostic or a software update via the phone line.

Option R

Automatic cleaning of the coating edges: on both sides, the remaining emulsion is wiped off with moistened wiper rolls. The wiper rolls are automatically moistened and washed out.

Option Z

- Additional pneumatic screen holders for a simultaneous coating of two screens.

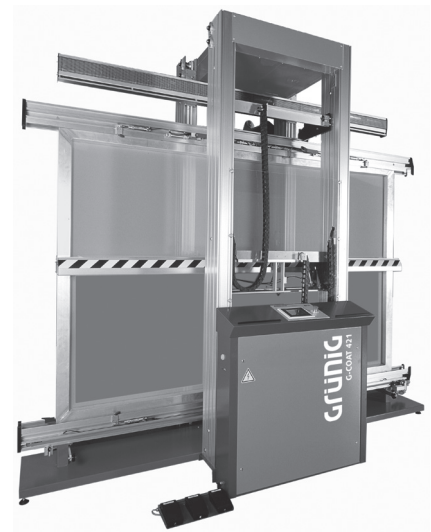

Screen format	SB Screen width	mm	1500-5000
	SH Screen height	mm	1250-8000
	Frame profile height	mm	40-200
	Frame profile thickness	mm	30-60
Overall sizes	Width	mm	SB+440
	Height	mm	SH+950
	Depth	mm	1325
Power supply	Voltage	V	3x400+N+PE 3x220+PE
	Frequency	Hz	50/60
Compressed air	Pressure	Bar	7
	Consumption	L/min	10
Permanent sound pressure level		dB (A)	<70

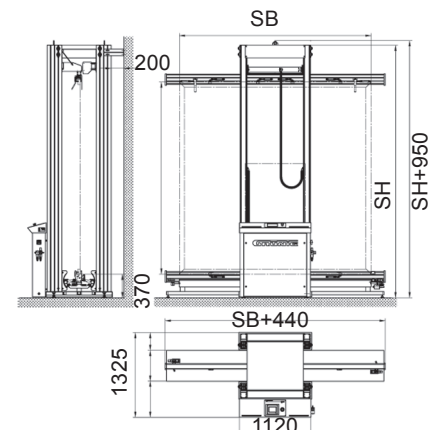

All measures in mm



The machine is in compliance with the EU machinery directives (EC conformity)

Technical changes are reserved
November 14